

1. SCOPE

This document describes the performance characteristics and testing methods for Polymer Li ion batteries

2. PRODUCT TYPE AND MODEL NUMBER

2.1 PRODUCT TYPE

Polymer Lithium-ion Battery

2.2 MODEL NUMBER

LP263050

SPECIFICATION

No.	Item	Characteristics	Remarks
3.1	Nominal Capacity	Minimum:320mAh Typical:330mAh	Fully charged @1C to 4.2V for 2.5 hrs, then discharge to 3.0V @ 0.2C.
3.2	Nominal Voltage	3.7V	
3.3	Charging Cut-off Voltage	4.2V	
3.4	Discharge Cut-off Voltage	3.0V	
3.5	Maximum Constant Charging Current	320mA (1.0C)	
3.6	Maximum Continuous Discharging Current	640mA (2.0C)	
3.7	Operating Temperature	Charge 0 ~ 45°C Discharge -20 ~ 60°C	
3.8	Storage Temperature	-20 ~ 45°C for 1Month -20 ~ 35°C for 6Months	
3.9	Weight	11g	Approximate value
3.10	Storage Voltage	3.80-3.90V	
3.11	Environmental request	RoHS	If the materials of the product and packaging accord with RoHS standard , there will be a RoHS Id on the box.

3. Dimensions

Please refer the drawing in appendix.

4. Appearance

No scratches, dirt, defect, leakage of electrolyte or gassing should be observed as a new product.

5. Characteristics

6.1 Electrochemical performance characteristics

No.	Item	Testing Method	Requirements
1	Fully Charged State	CCCV or Constant current charge to 4.2V @1C follow by a constant voltage holding at 4.2V until current drops below 20±5mA.	

2	Rated Capacity	CCCV at 4.2V (per 6.1.1) at room temp. (20±5°C), rest for 1-2 hrs then discharge at a constant current of 0.2C to 3.0V, testing will be terminated by either 5 cycles or any one discharge time exceeds 5 hrs	≥320mAh
3	Cycle Life @25°C	Discharge to 3.0V @1C, then CCCV charge to 4.2V, rest for 10 min. discharge @ 1C to 3.0V and rest for 10 min. Continue the charge/discharge cycles until discharge capacity lower than 80% of rated capacity.	Cycle life ≥300
4	Internal Impedance	Internal impedance is measured on a 50% charged battery at 1KHz AC at ambient temperature (20±2) °C.	≤80mΩ
5	Capacity Retention	Fully charge cells per 6.1.1, store them at (20±2)°C for 28 days, then discharge the cells to 3.0V at 0.2C.	Discharge capacity≥ 300mAh
6	High Temperature Characteristics	Fully charge cells per 6.1.1, store them at (55±2)°C for 2 hours, then discharge the cells to 3.0V at 0.2C.	Discharge capacity≥ 300mAh
7	Low Temperature Characteristics	Fully charge cells per 6.1.1, store them at (-10±2)°C for 16~24 hours, then discharge the cells to 3.0V at 0.2C.	Discharge capacity≥ 290mAh
8	Cell Voltage during Transportation	Check open circuit voltage (OCV) of cells prior to the delivery to customers	≥3.75V

6.2 Safety characteristic

No.	Item	Test Method	Requirements
1	Overcharge	Discharge cells to 3.0V at 1C, then charge to 4.8V at 3C and rest for 8 hours.	No fire No explosion
2	Over Discharge	Fully charge cells per 6.1.1, then discharge the battery to 3.0V with 0.2CmA at room temperature, connect with external load of 30Ω for 24hours.	No fire No explosion
3	Hot Oven Test	Put a fully charged battery in a forced air oven and raise the temperature at 5±2°C /min. to 130±2°C Rest for 10 minutes.	No fire No explosion

6.3 Reliability

No.	Item	Test Method	Requirements
1	High Temperature Test	Fully charged per 6.1.1, then stored the cells at $60\pm 2^{\circ}\text{C}$ for 2 hours.	Electrochemical performance, visual test not changed
2	Low Temperature Test	Fully charge cells per 6.1.1, store them at $-20\pm 2^{\circ}\text{C}$ for 2 hours. Then, cells are placed at room temperature for 3 hours.	No appreciable alternation electrochemically and visually
3	Humidity Test	Fully charge cells per 6.1.1, stored them at $40\pm 2^{\circ}\text{C}$ with 90% ~ 95RH% for 48 hours. Then the cells are placed at room temperature to "dry out" for 2 hours.	No appreciable alternation electrochemically and visually

6. Standard Testing Environment

Temperature : $25\pm 2^{\circ}\text{C}$

Relative humidity : $45\pm 20\%$ (unless specially requested)

7. Required Protective Functions

To ensure safety, the cells need to be assembled with PTC and protective circuitry to prevent abusive situations occur such as over charge and over discharge or over current. The charger and protective circuitry should be consistent with the requirements listed below:

No	Device	Items	Requirements
1	Charger	Charge termination voltage	$4.200\pm 0.049\text{V}$
2	Protective Circuitry (For reference only)	Overcharge detection voltage	$4.275\pm 0.025\text{V}$
3		Overcharge release voltage	$4.175\pm 0.050\text{V}$
4		Discharge termination voltage	$3.00\pm 0.10\text{V}$
5		Over discharge detection voltage	$3.0\pm 0.08\text{V}$
6		Over discharge release voltage	$3.0\pm 0.10\text{V}$
7		Over discharge detection value	$2.7\pm 0.2\text{A}$

8. Warranty

Warranty period for this product is 12months starting from the date when the products left the door of manufacturer.

10. Liability

The user has to operate the products according to the instructions printed on the battery label or follow the advices described in this "Product Specification for Polymer Lithium Ion Batteries. In case the battery were overheated or even catch fire or explosion caused by mishandling of the user side, manufacturer will not be liable for the lose caused by any of such mishandling.

PRODUCT SPECIFICATION FOR 263050

11. Battery Packing Label

The following warnings should be indicated on the battery pack labels.

Use a specified charger.

Do not throw the battery into fire, or heat.

Do not short-circuit the battery terminals.

Do not disassemble the battery.

12. Warnings and Cautions in Handling the Lithium-ion Battery

To prevent potential leaking, overheating or explosion of batteries please be advised to take following precautions:

WARNINGS!

Do not immerse the battery in water or seawater, and keep the battery in a cool dry environment during stands by period.

Do not use or leave the battery near a heat source such as fire or heater.

When recharging, use the battery charger specifically for that purpose.

Do not reverse the position (+) and negative (-) terminals.

Do not connect the battery to an electrical outlet.

Do not dispose the battery in fire or heat.

Do not short-circuit the battery by directly connecting the positive (+) and negative (-) terminal with metal objects such as wire.

Do not transport or store the battery together with metal objects such as necklaces, hairpins etc.

Do not strike or throw the battery against hard surface.

Do not directly solder the battery and pierce the battery with a nail or other sharp object.

Outer metal conduct can not contact the aluminum layer in AL laminate film, especially with electrification ,which will be "black spot "and swelling easily.

Do not use sharp things to hit the battery.

CAUTIONS!

Do not use or leave the battery at very high temperature (for example, at strong direct sunlight or in a vehicle in extremely hot weather). Otherwise, it can overheat or fire or its performance will be degenerate and its service life will be shortened.

Do not use it in a location where static electricity is rich, otherwise, the safety devices may be damaged, causing a harmful situation.

In case the electrolyte get into the eyes due to the leakage of battery, do not rub the eyes! Rinse the eyes with clean running water, and seek medical attention immediately. Otherwise, it may injure eyes or cause a loss of sight.

If the battery gives off an odor, generates heat, becomes discolored or deformed, or in any way appear abnormal during use, recharging or storage, immediately remove it from the device or battery charger and place it in a contained vessel such as a metal box.

PRODUCT SPECIFICATION FOR 263050

In case the battery terminals are contaminated, clean the terminals with a dry cloth before use. Otherwise power failure or charge failure may occur due to the poor connection between the battery and the electronic circuitry of the instrument.

Be aware discarded batteries may cause fire, tape the battery terminals to insulate them before disposal.

Attachment : Unit : mm

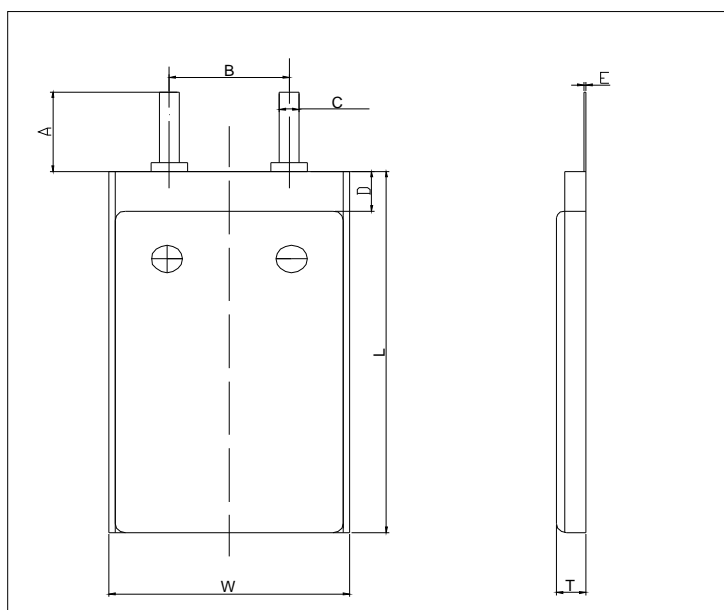

Item	Description	Dimension and specification
T	Thickness	≤2.6mm
W	Width	≤30.0mm
L	Length	≤50mm
A	Tab length	18.5~20.5mm
B	Tab center distance	1.35~1.5mm
C	Tab width	2.85~3.05mm
D	Top sealing width	3.25~4.30mm
E	Tab thickness	0.1mm
Cap	Capacity	320mAh
Imp	Impedance	80mΩ Max
V	Voltage	3.78~3.85V

NOTICE : Any question you must apprise us in a week, or the standards will be accepted.