

This is controlled document.  
 Hardcopy to be endorsed by authorized person.  
 Check with Issuing Officer or SAP system for latest update.

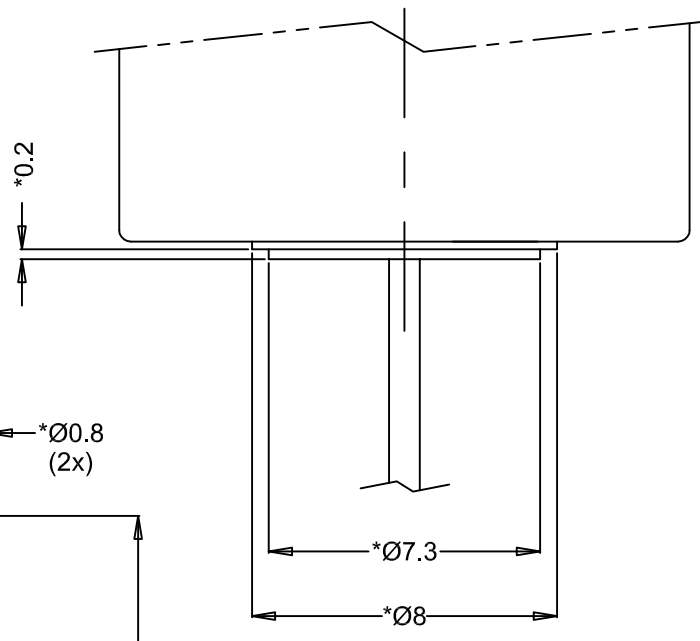

Detail X  
 Scale 5 : 1

Front artwork

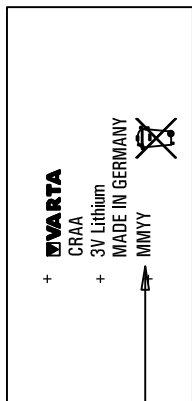

Monthly code

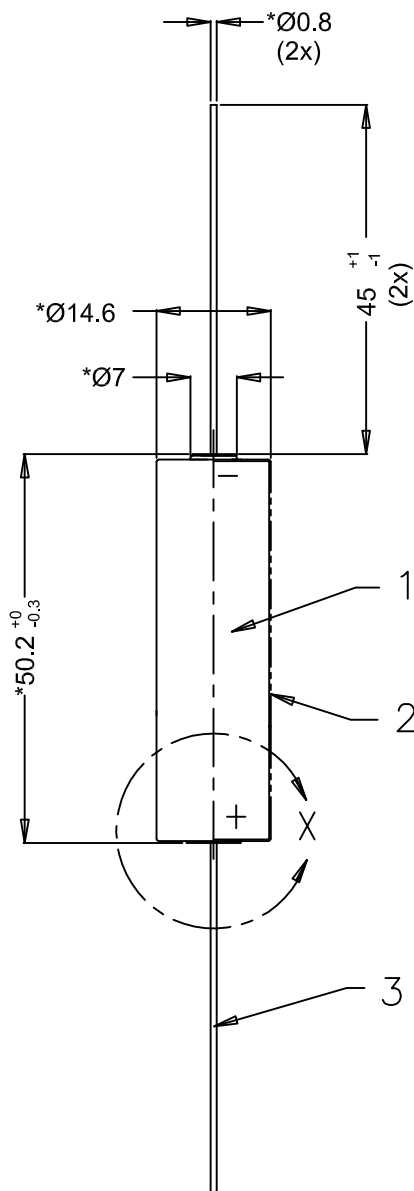

Rear artwork

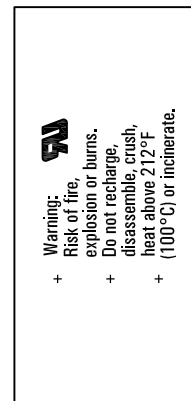

Note: 1) \* Dimensions for reference only  
 2) Use UL approved green shrink sleeve

1	R123/08	To add in printed sleeve the crossed-out wheeled bin symbol	2008-04-29	Eka
0		Refer to # 001284	1999-09-06	Tatang
No	AO No	Revisions	Date	Name

Material:		Description:		
Refer to part list no : 071783		CR AA CD battery with shrink sleeve & solder tags		
Projection:	Prepared & Checked	Verified & Approved	Dwg. No: 071783	401
Dimensions in mm	1999-09-06	Tatang	VKB Order No: 06117 501 301	
Tolerance: As specified				
Scale: 1 : 1				

Rights reserved to make technical changes, as a result of further development, without notice. This drawing is the property of VARTA Microbattery and must not be copied or disclosed to a third party without the written consent of VARTA Microbattery.

