

3.2

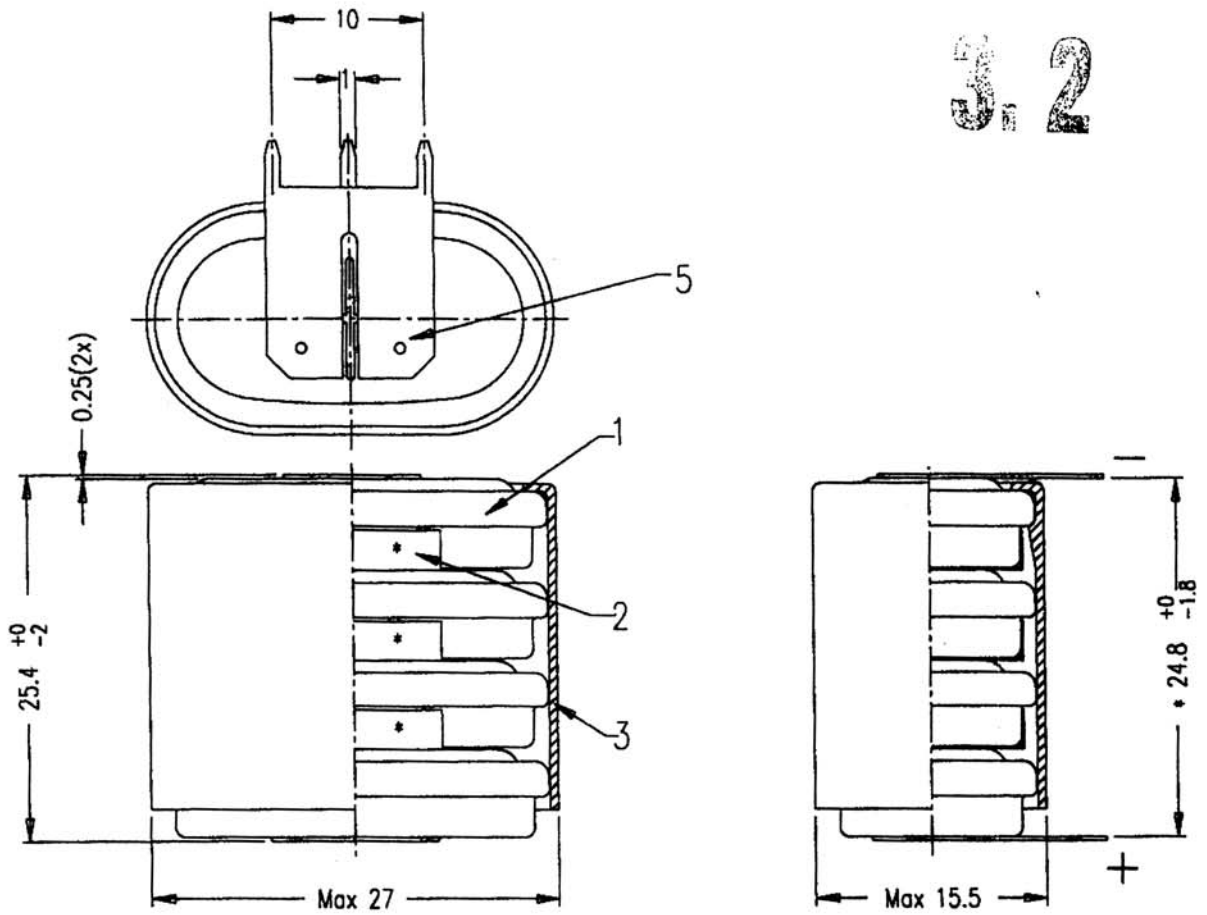

Printing is on this side of the casing

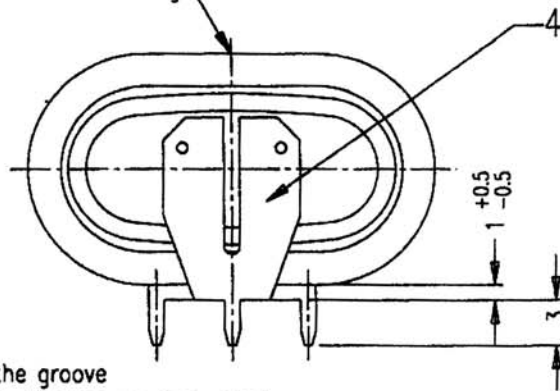

- Note: 1) No welding onto the groove
- 2) For typical PCB-application we recommend to use VARTA-Mempac batteries
- 3)\* For reference only

Approximate weight of battery : 25.5g

No.	Alterations:	Date:	Name:	Dimensions in mm	Material:
				Tolerance: DIN 7168 Medium	Refer to part list no: 070956
				Projection:	Description:
				Scale: 2 : 1	4/V150H battery with snap-on plastic casing & solder tags
				Date: Name:	
				Prepared: 1997-10-24 C.Y.LEE	
				Approved: 1998-	
RIGHTS RESERVED TO MAKE TECHNICAL CHANGES, AS A RESULT OF FURTHER DEVELOPMENT, WITHOUT NOTICE. THIS DRAWING IS THE PROPERTY OF VARTA BATTERIES PTE LTD AND MUST NOT BE COPIED OR DISCLOSED TO A THIRD PARTY WITHOUT THE WRITTEN CONSENT OF VARTA BATTERIES PTE LTD.				<b>VARTA</b> THE BATTERY EXPERTS	Dwg. No: 070956 40
					VKB Order No: 55615 604 059
					Orig No: