

FILE TYPE		DWG NO#.	
BATTERY		REV.	A0
DRAWING	NICD BATTER PACK SC1500mAh 3.6V	PAGE.	1/1

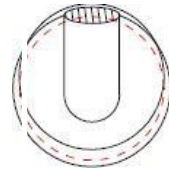
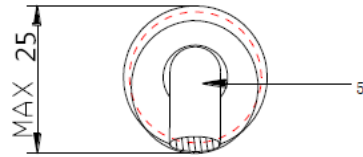
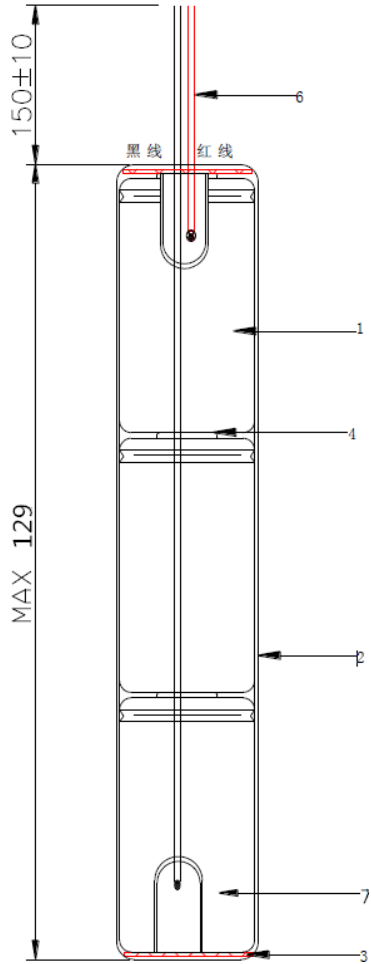

7	Shrink tube	Black
6	Wire	UL1015 20#
4/5	Connector	NI plated
3	Washer	Red
2	PVC	White
1	Cell	IGB NICD SC1500HT
NO#	MATERIAL	SPEC

	SIGNATURE	DATE	ID-SC1500HT*3	CLIENTS P/N#.	
DRN	XIAO YONG CHEN	2019-12-20		DWG NO#	
CHEX	YONG KUI LIU	2019-12-20		UNIT	mm
ENGR	XIAO FEI TANG	2019-12-20		SCALE	0.9:1
				REV	A/0